

零件手册 PARTS BOOK

选购零件时，请注明序号、件号。

Please confirm the relative applications Ref. No, part No. when buying the parts.

1. 机壳部件 Arm bed components

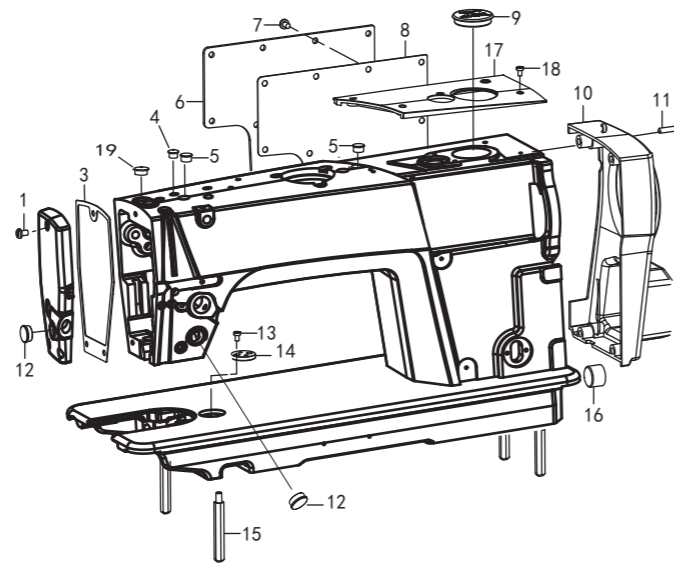

2. 上轴装置/Shaft mechanism

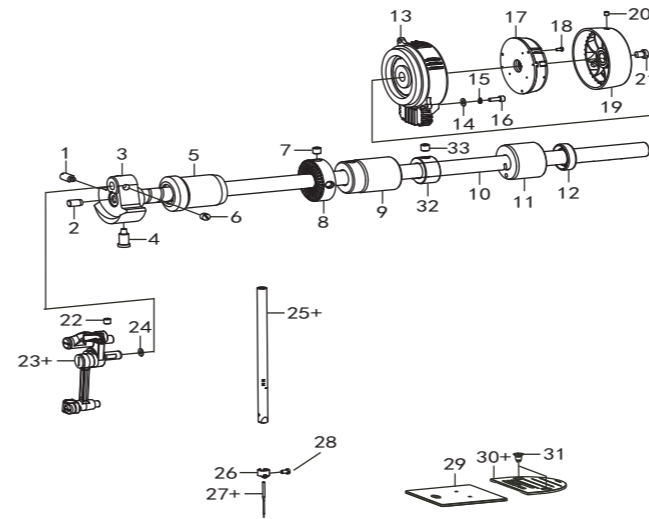

3. 压脚装置/Presser foot mechanism

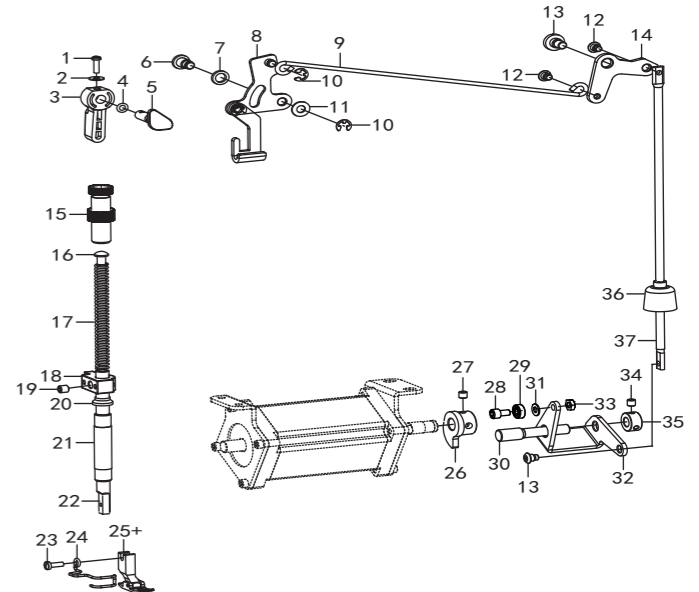

4. 送料装置/Feed mechanism components

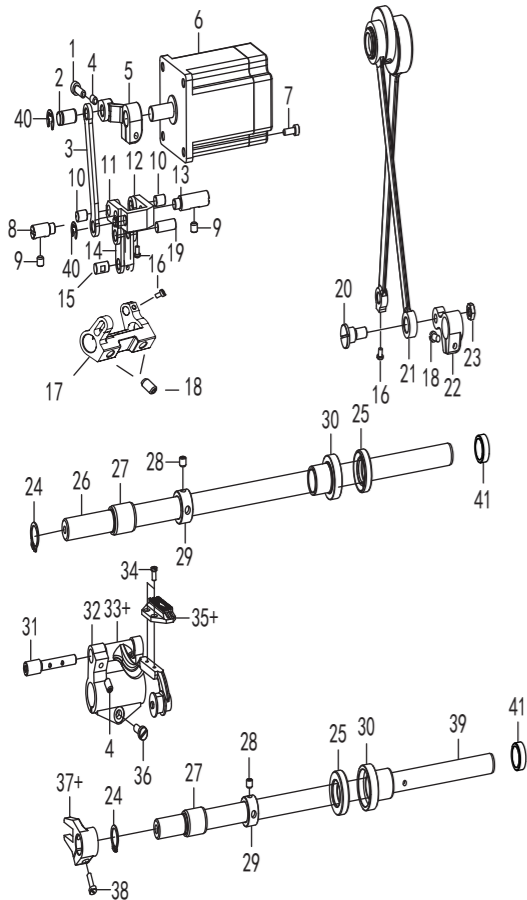

序号	物料号	数量	物料名称	Description
1	062711212	3	螺钉 SM4. 76×32-12	SCREW PAN SM4. 76×32-12
2	167012001	1	面板	FACE PLATE
3	167012101	1	面板垫	GASKET
4	115010801	2	橡皮塞 8.5	RUBBER 8.5
5	101011001	2	橡皮塞 12.2	RUBBER 12.2
6	115010401	1	后窗板	SIDE PLATE
7	062501016	9	螺钉 M5×10	SCREW PAN M5×10
8	115010501	1	后窗板衬垫	GASKET
9	168010901	1	橡皮塞 37.8	RUBBER 37.8
10	168011001	1	马达罩	MOTOR COVER
11	018502036	4	螺钉 M5×20	SCREW PAN M5×20
12	115010701	3	橡皮塞 15.5	RUBBER 15.5
13	062400616	1	螺钉 M4×6	SCREW PAN M4×6
14	115011201	1	卷边器座	EDGE WINDING DEVICE
15	168011701	4	底板支柱	BED SCREW STUD
16	101011401	1	橡皮塞 21	RUBBER 21
17	168012001	1	顶盖	UPPER COVER
18	168012501	5	螺钉 M3×8	SCREW PAN M3×8
19	101011001	1	孔塞 12.2	Rubber plug 12.2
1	018501636	1	螺钉 M5×16	SCREW PAN M5×16
2	168040201	2	连杆轴	F-REGULATOR CONNECT ROD
3	168040301	1	倒缝连杆	SCREW PAN SM4. 37
4	014680632	2	螺钉 SM4. 37	INVERTED CAM
5	168040501	1	倒缝曲柄	BACKSEWING STEPPING MOTOR
6	168040601-1	1	倒缝步进电机 (琦星)	SCREW PAN M4×14
7	018401432	4	螺钉 M4×14	ADJUSTING LINK FULCRUM SHAFT
8	101061501	1	摆动板座左销	SCREW PAN SM5. 95
9	014760832	2	螺钉 SM5. 95	FEED LINK STUD
10	101061801	2	曲柄连杆短销	LEVEL FEED REGULATOR
11	168041101	1	切换器	FEED ROCKER LINK
12	101061601	2	曲柄短连杆	ADJUSTING LINK FULCRUM SHAFT
13	168041301	1	切换器右销	FEED ROCKER LINK
14	101061701	2	曲柄长连杆	FEED ROCKER LINK
15	101060901	1	送料连杆销	WALKING FOOT PIN
16	101022801	5	螺钉 SM3. 57	SCREW PAN SM3. 57
17	152303101	1	针送料驱动下曲柄	FEED ROCKER SHAFT CRANK
18	152303201	2	螺钉 SM7. 14	SCREW PAN SM7. 14
19	101063401	1	送料曲柄销	NWALKING FOOT PIN
20	101061101	1	连杆轴位螺钉	HINGE SCREW
21	101060102	1	连杆组件 H	CONNECTING ROD ASM
22	101063601	1	抬牙后曲柄	READ CRANK ASM
23	101063701	1	螺母 SM5. 95	NUT SM5. 95
24	048140142	2	挡圈 C14	RING C14
25	125064301	2	油封	OIL SEAL
26	168042601	1	送布轴	FEED ROCKER SHAFT
27	101063101	2	送布轴前轴套	FEED ROCKER SHAFT METAL
28	014770632	4	螺钉 SM6. 35	SCREW PAN SM6. 35
29	101062901	2	送布轴挡圈	THRUST COLLAR
30	125064201	2	送布轴中套	FEED ROCKER SHAFT METAL
31	101062201	1	牙架销	FEED BAR SHAFT
32	101062501	1	牙架座	FEED ROCKER
33	101062301	1	牙架	FEED BAR
34	115047001	2	螺钉 SM3. 18	SCREW PAN SM3. 18
35+	115046901	1	送料牙 M	FEED DOG M
35+	115046902	1	送料牙 H	FEED DOG H
36	101062701	1	螺钉 SM5. 95	SCREW PAN SM5. 95
37	101063901	1	抬牙叉形曲柄	DRIVING SHAFT CRANK ASM
38	115072601	1	螺钉	SCREW PAN
39	168043901	1	抬牙轴	FEED DRIVING SHAFT
40	048050342	2	卡簧 E5	RING E5
41	125013001	2	橡皮塞 15.3	RUBBER 15.3

序号	物料号	数量	物料名称	Description
1	101031601	1	螺钉 SM7. 14	SCREW PAN SM7. 14
2	101031901	1	橡皮塞 6.8	RUBBER 6.8
3	125031501	1	针杆曲柄	COUNTER WEIGHT
4	101031801	1	螺钉 SM7. 14	SCREW PAN SM7. 14
5	101032001	1	上轴前轴套	MAIN SHAFT BUSHING FRONT
6	014770632	2	螺钉 SM6. 35	SCREW SM6. 35
7	012060832	2	螺钉 M6×8	SCREW PAN M6×8
8	101032101	1	绕线驱动轮	BOBBIN WINDER DRIVING WHEEL
9	168020901	1	上轴中轴套	BUSHING INTERMEDIATE
10	101033801	1	上轴	MAIN SHAFT
11	101032701	1	上轴后轴套	MAIN SHAFT BUSHING REAR
12	115024001	4	油封	OIL SEAL
13	169024201	1	马达组件	SERVO MOTOR ASSY
14	028050246	3	弹性垫圈	SPRING WASHER
15	025050132	3	垫圈 M5	WASHER M5
16	018501436	3	螺钉 M5×14	SCREW PAN M5×14
17	115020101	1	编码器	FILM ROTATING AND ENCODER
18	062350516	3	螺钉 M5×5	SCREW PAN M5×5
19	115025301	1	手轮	HANG WHEEL ASM
20	012501032	2	螺钉 M5×10	SCREW PAN M5×10
21	115025401	1	螺钉 SM8. 73	SCREW PAN SM8. 73
22	012060832	1	螺钉 M6×8	SCREW PAN M6×8
23+	152301401	1	挑线杆组件 M	THREAD TAKE-UP LEVER ASM M
23+	152301402	1	挑线杆组件 H	THREAD TAKE-UP LEVER ASM H
24	115021401	1	垫圈	WASHER
25+	101040401	1	针杆 M	NEEDLE BAR M
25+	101040402	1	针杆 H	NEEDLE BAR H
26	101041101	1	针杆过线环	NEEDLE BAR THREAD GUIDE
27+	115024101	1	机针 DB×1 14	NEEDLE DB×1 #14
27+	115024102	1	机针 DP×5 20	NEEDLE DP×5 #20
28	101041001	1	支针螺钉 SM3. 18	SCREW PAN SM3. 18
29	101011801	1	推板组件	SLIDE PLATE COMPONENTS
30+	115023401	1	针板 M	THREAD PLATE M
30+	112023402	1	针板 H	THREAD PLATE H
31	115023501	2	螺钉 SM4. 37	SCREW PAN SM4. 37
32	101032501	1	上轴挡圈	THRUST COLLAR
33	014770632	1	螺钉 SM6. 35×40-6	SCREW SM6. 35×40-6

5. 旋梭装置/ Hook components

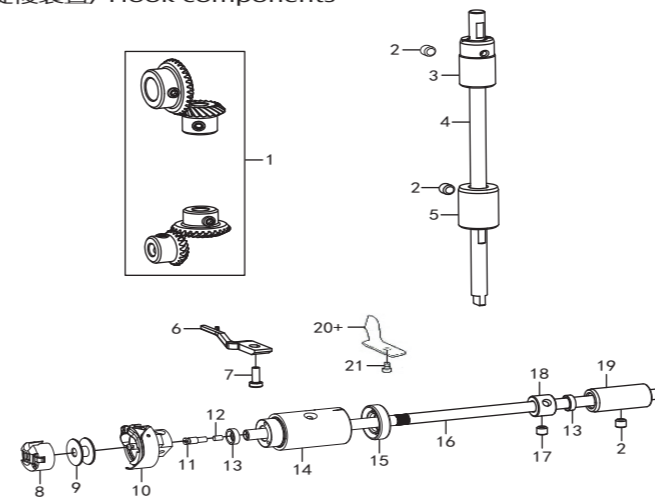

序号	物料号	数量	物料名称	Description
1	101054501	1	螺钉 SM3. 57	SCREW SM3. 57
2	101054601	1	垫圈 3.7	WASHER 3.7
3	168030301	1	抬压脚扳手	HAND LIFTER
4	081004070	1	O型圈 P4	RING P4
5	101054701	1	抬压脚凸轮	PRESS FOOT LIFTER CAM ASM
6	101052001	2	前杠杆螺钉	LINK SHAFT
7	101052101	2	防油橡胶垫 (薄)	WASHER
8	168031001-1	1	抬压脚前杠杆	HANK LIFTER LINK
9	167034401	1	抬压脚拉杆	LIFTING LEVER LINK
10	048050342	3	卡簧 E5	SNAP RING E5
11	101056301	1	垫圈 6.35	WASHER 6.35
12	115034301	3	轴位螺钉 SM4. 76	SCREW SM4. 76
13	115034501	1	轴位螺钉 SM6. 35	SCREW SM6. 35
14	167052401	1	抬压脚右杠杆	LIFT KNEE CONTROL LEVER
15	168031501	1	调压螺钉组件	PRESSURE REGULATING BOL
16	101050301	1	调压导杆	PRESSER GUIDE BAR
17	101050401	1	调压簧	PRESSER SPRING
18	101050601	1	压杆导架	NEEDLE BAR GUIDE BAACKET
19	014770632	1	螺钉 SM6. 35	SCREW SM6. 35
20	101050901	1	压杆套防油圈	SHOCK PAD
21	101051001	1	压杆衬套	PRESSER BAR BUSHING LOWER
22	101050501	1	压杆	PRESSER BAR
23	115031001	1	螺钉 SM3. 57	SCREW SM3. 57
24	101051301	1	护指器	PROTECT SHELF
25+	101051201	1	压脚 M	MPRESSER FOOT ASM M
25+	101051202	1	压脚 H	MPRESSER FOOT ASM H
26	169033301	1	抬压脚凸轮	HAND LIFTER CAM
27	014600832	2	螺钉 M6×8	SCREW PAN M6×8
28	118601232	1	螺钉 M6×12	SCREW PAN M6×12
29	169034001	1	轴承	BEARING
30	168033101	1	抬压脚曲柄轴	PRESSER FOOT CRANK SHAFT
31	025060236	1	垫片	WASHER
32	168033201	1	抬压脚驱动曲柄	PRESSER FOOT DRIVING CRANK
33	021600106	1	螺母 M6×0. 75	NUT M6×0. 75
34	012500632	2	螺钉 M5×6	SCREW PAN M5×6
35	168033501	1	曲柄轴挡圈	SET SCREW COLLAR
36	168033601	1	橡胶提升杆橡皮塞	RUBBER CAP
37	168033701	1	抬压脚顶杆	CONNECTING ROD VERTICAL
1	101041301	1	伞齿轮组件	BEVEL GEAR ASSY
2	014760832	3	螺钉 SM5. 95	SCREW SM5. 95
3	168050301	1	竖轴上轴套	VERTICAL SHAFT BUSH U
4	101041901	1	竖轴	VERTICAL SHAFT
5	101042201	1	竖轴下轴套	VERTICAL SHAFT BUSH D
6	115072201	1	旋梭定位钩	HOOK STOPPER
7	115072601	1	螺钉 SM4. 37	SCREW PAN SM4. 37
8	115072701	1	梭芯套组件	BOBBIN GASE ASSY
9	115072401	1	梭芯	BOBBIN
10	115072301	1	旋梭组件	ROTARY HOOK ASSY
11	115071401	1	油盖螺钉	OIL COVER SCREW
12	115071901	1	油芯	OIL CORE
13	115073401	2	油封	OIL SEAL
14	168051401	1	下轴前套	PUMP BUSH
15	115071601	1	油封	OIL SEAL
16	101042901	1	旋梭轴	ROTARY HOOK SHAFT
17	014770432	2	螺钉 SM6. 35	SCREW PAN SM6. 35
18	115072001	1	紧圈	SET SCREW COLLAR
19	168051901	1	下轴后轴套	BUSHING THREAD FINGER
20+	125082201	1	分线器	LOWER THREAD FINGER
20+	168052001	1	分线片 (单刀)	LOWER THREAD FINGER
21	101080701	1	螺钉 SM3. 57	SCREW PAN SM3. 57

6. 供油润滑装置/Lubrication

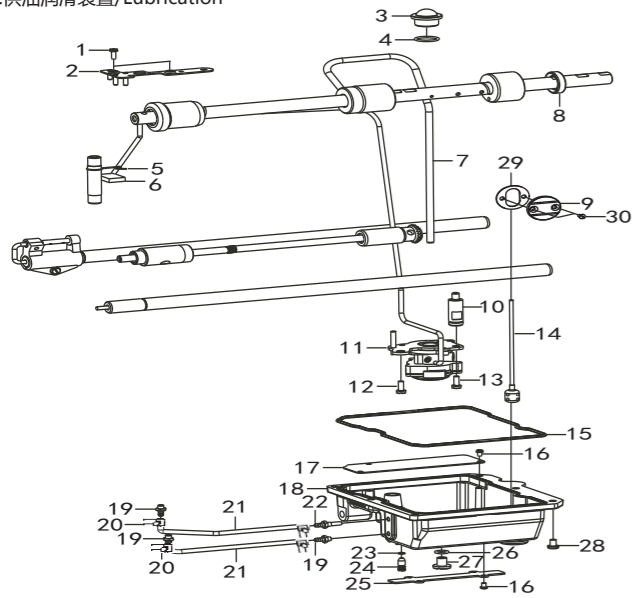

序号	物料号	数量	物料名称	Description
1	115031001	2	螺钉 SM3. 57	SCREW PAN SM3. 57
2	101090701	1	油线固定板	OIL THREAD BORAD ASM
3	101090901	1	油窗	OIL GAUGE WINDOW
4	101091001	1	O 型圈	O RING
5	101090601	1	油毡夹	OIL FELT PRESSER
6	101090301	1	油毡	FELT
7	101091801	1	上轴供油管	MAIN SHAFT OIL TUBE
8	115024001	1	油封	OIL SEAL
9	168063401	1	油量视窗板	OIL GAGE WINDOW
10	101091601	1	油泵连接螺钉	OIL PUMP SUPPORT
11	168061401	1	油泵组件	PUMP UNIT
12	101074701	1	螺钉 SM5. 95	SCREW PAN SM5. 95
13	115072601	1	螺钉 SM4. 37	SCREW PAN SM4. 37
14	168061701	1	浮球组件	FLOAT ASSY
15	168061802	1	油盒密封圈	OIL BOX SEALING RING
16	062350616	7	螺钉 M3. 5×6	SCREW PAN M3. 5×6
17	168062002	1	油盒盖	THE OIL BOX COVER
18	168062102	1	油盒	OIL BOX
19	115080401	3	供油口	OIL FEEDING PIPE
20	115085501	4	油管夹	OIL PIPE CLAMP
21	168062401	2	油管 L=	VINYL TUBE L=
22	168062601	1	供油口	OIL FEEDING PIPE
23	081004870	1	O 型圈 P4	O RING P4
24	115081501	1	调节螺钉	ADJUSTING SCREW
25	124123201	1	电线压板	WIRE PLATE
26	168063001	1	O 型圈	O RING
27	115080901	1	放油螺钉 M8	SCREW PAN M8
28	018502032	8	螺钉 M5×20	SCREW PAN M5×20
29	168063501	1	油窗防油垫	OIL WINDOW CUSHION
30	115110401	1	螺钉SM3. 57×40-5	SCREW PAN SM3. 57×40-5

7. 穿线装置/Threading mechanism

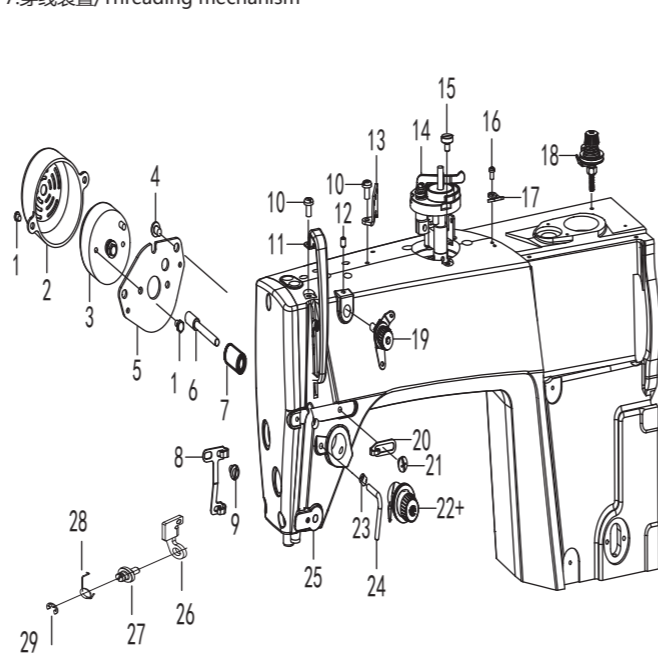

序号	物料号	数量	物料名称	Description
1	062400616	4	螺钉 M4×6	NEEDLE CLAMP SCREW PAN M4×6
2	168070201	1	电磁铁罩	SOLENOID COVER
3	168070301	1	松线电磁铁组件	ELEC TENSION RELEASE ASSY
4	062500816	2	螺钉 M5×8	SCREW PAN M5×8
5	168070802	1	电磁铁安装板	SOLENOID SETTING PLATE
6	167122801	1	夹线轴	TENSION SHAFT
7	167123101	1	松线杆衬套	Loose rod bushing
8	125020101	1	面线线勾	FACE PLATE THREAD GUIDE
9	062400616	1	螺钉 M4×6	SCREW PAN M4×6
10	101010901	2	螺钉 SM4. 76	SCREW PAN SM4. 76
11	101010801	1	挑线杆防护罩	THREAD TAKE-UP LEVER COVER
12	101022201	1	螺钉 SM4. 76	SCREW PAN SM4. 76
13	115090301	1	穿线板	SPOOL PLATE
14	115100501	3	螺钉 M5×6	SCREW PAN M5×6
15	101022501	1	绕线器组件	BOBBIN WINDER ASM
16	101022801	2	螺钉 SM3. 57	SCREW PAN SM3. 57
17	101022701	1	切刀	KNIFE
18	168072101	1	绕线器夹线组件	BOBBIN THREAD TENSION ASM
19	168072201	1	调线夹线器组件	THREAD TENSION ASM
20	115090701	1	机壳线导向 R	FRAME THREAD GUIDE R
21	115090801	1	螺钉 M5×6	SCREW PAN M5×6
22+	168072501	1	夹线器组件 M	THREAD TENSION ASSY M
23	168072601	1	夹线器组件 H	THREAD TENSION ASSY H
24	014760832	2	螺钉 SM5. 95	SCREW PAN SM5. 95
25	115090501	1	线导向	P-BAR BRACKET THREAD GUIDE
26	168072801	1	电子夹线器	THREAD TAKE-UP
27	167035101	1	松线传动杆	Loose wire transmission lever
28	167305201	1	轴位螺钉SM4. 76	Axis screw SM4. 76
29	048040342	1	弹簧	Spring
30	115100401	1	卡簧E4	Clamp spring E4

8. 切线装置/Thread trimmer mechanism

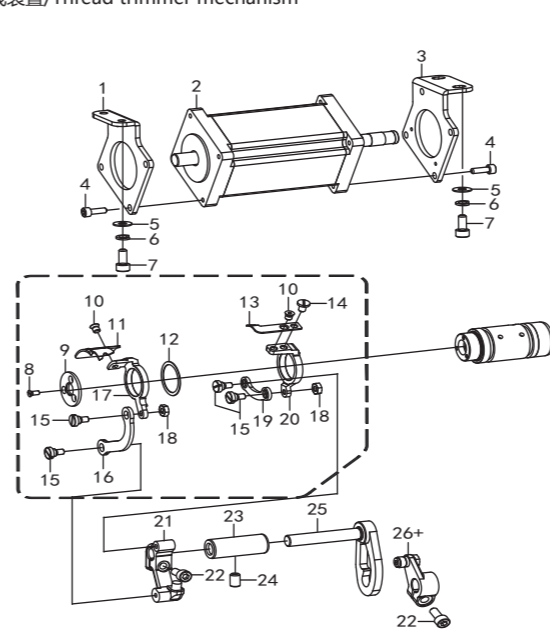

序号	物料号	数量	物料名称	Description
1	168080101	1	电机安装板 L	SOLENOID SETTING PLATE L
2	168080201-1	1	剪线电机	MOTOR
3	168080301-1	1	电机安装板 R	SOLENOID SETTING PLATE R
4	018401232	8	螺钉 M4×12	SCREW PAN M4×12
5	025050132	4	垫圈 M5	WASHER M5
6	028050246	4	弹簧垫圈	SPRING WASHER
7	018501232	4	螺钉 M5×12	SCREW PAN M5×12
8	125080401	3	螺钉 M3×7	SCREW PAN M3×7
9	125082501	1	动刀压板	KNIFE HOLDER PRESSER PLATE
10	115111301	3	螺钉 SM4. 37	SCREW PAN SM4. 37
11	125081501	1	下动刀	MOVABLE KNIFE D
12	125081801	1	垫圈	WASHER
13	125081401	1	上动刀	MOVABLE KNIFE U
14	125080501	1	螺钉 SM4. 37	SCREW PAN SM4. 37
15	125080601	4	螺钉 M4	SCREW PAN M4
16	125082001	1	刀架长连杆	KNIFE HOLDER CONNECTING ROD L
17	125081701	1	下刀架	HOLDER M-KNIFE D
18	021400306	2	螺母 M4	NUT M4
19	125081901	1	刀架短连杆	KNIFE HOLDER CONNECTING ROD S
20	125081601	1	上刀架	HOLDER M-KNIFE U
21	125082101	1	切线曲柄	THREAD TRIMMER LEVER
22	018501432	2	螺钉 M5×14	SCREW M5×14
23	115112301	1	叉轴轴套	FORKED SHAFT BUSH
24	014760832	1	螺钉 SM5. 95	SCREW PAN SM5. 95
25	168082001	1	切线曲柄	THREAD TRIMMER LEVER
26	169110102	1	切线驱动曲柄	THREAD TRIMMER CAM LEVER SHAFT

9. 倒缝开关装置/Quick reverse switch mechanism

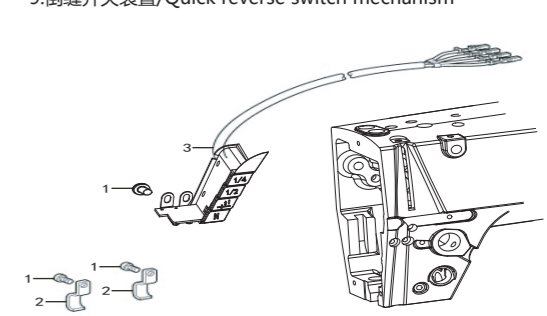

10. 控制部分/Control components

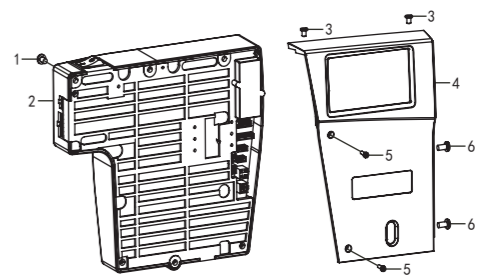

序号	物料号	数量	物料名称	Description
1	062500816	4	螺钉 M5×8	SCREW PAN M5×8
2	115140301	2	电线夹 U2	CORD HOLDER U2
3	168090101	1	倒缝开关组件	R-SWICH ASSY

序号	物料号	数量	物料名称	Description
1	018502032	3	螺钉 M5×20	SCREW PAN M5×20
2	168100201-1	1	控制箱	CONTROL BOX ASSY
3	101020201	2	螺钉 SM4. 37×40-6	SCREW PAN SM4. 37×40-6
4	168100601	1	操作盒组件4. 3	OPERATION PANEL
5	168012501	2	螺钉 M3×8	SCREW PAN M3×8
6	062501016	2	螺钉 M5×10	SCREW PAN M5×10

11. 附件/Accessories

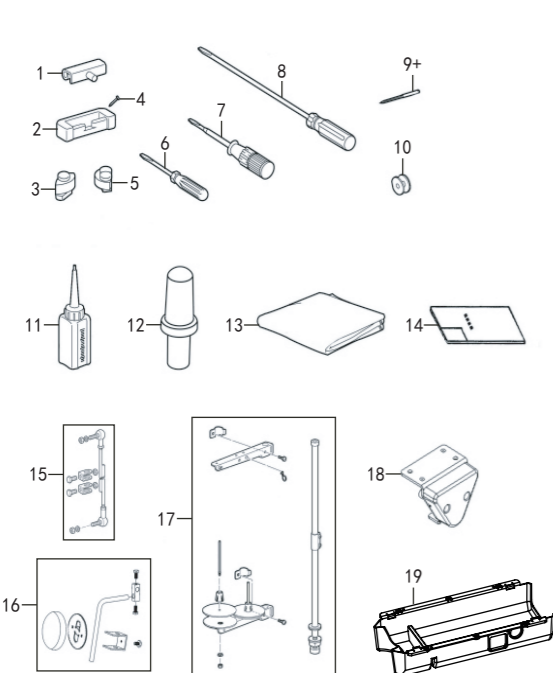

序号	物料号	数量	物料名称	Description
1	115150401	2	机头铰链	MACHINE HINGE PLATE
2	115150501	2	机头铰链套	HINGE SLEEVE HEAD
3	125120601	2	头部防震垫	QUAKEPROOF WASHER
4	115150701	4	钉	NAIL
5	125120801	2	头部防震垫	QUAKEPROOF WASHER
6	115151601	1	螺丝刀 (小)	SCREW DIRVER
7	115151701	1	螺丝刀 (中)	SCREW DIRVER
8	115151801	1	螺丝刀 (大)	SCREW DIRVER
9+	115024101	4	机针 DB×1 14	NEEDLE DB×1 14
9+	115024102	4	机针 DP×5 20	NEEDLE DP×5 20
10	115072401	3	梭芯	BOBBIN
11	115151001	1	中号油壶	OIL RESERIVIR
12	168111401	1	机头撑杆	HEAD REST
13	115151301	1	机头罩	HEAD COVER
14	168111601	1	零件手册	PARTS BOOK
15	115151901	1	连杆组件	CONNECTING ROD ASSY
16	115060101	1	膝控组件	KNEE LIFTER ASSY
17	115151401	1	线架组件 2DR	THREAD STAND ASM 2DR
18	169050101	1	膝靠组件	ELECTRONIC KNEE CONTROL ASSY
19	125103101	1	油盘	OIL PAN

12. 针送布部件 Rock Shaft Assembly

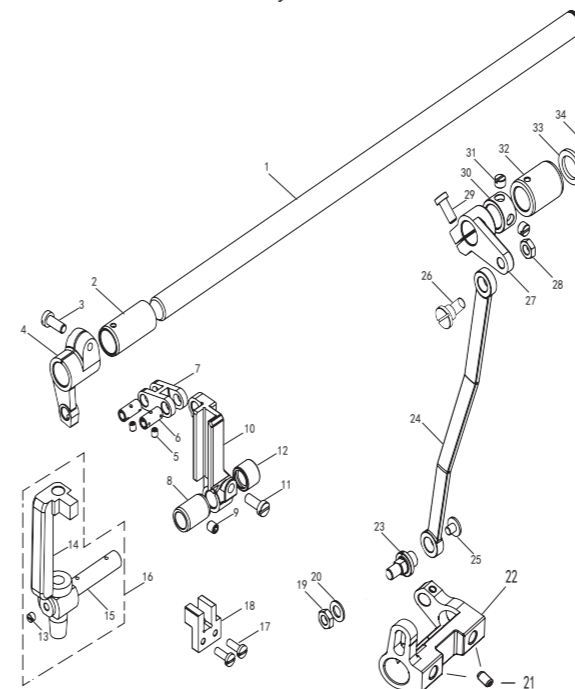

序号	物料号	数量	物料名称	Description
1	152300101	1	针送布摆动轴	Rock shaft
2	152300401	1	针送布摆动前轴套	Rock shaft bushing front
3	152300301	1	螺钉SM4. 76-28×12	Screw SM4. 76-28×12
4	152300201	1	针杆摆动曲柄	Driving crank front
5	152300701	2	螺钉SM3. 57-40×4	Screw SM3. 57-40×4
6	152300501	2	针杆摆动连杆销	Needle bar link pin
7	152300601	1	针杆摆动连杆	Driving link
8	152302201	2	针杆摆动架轴套	Bushing
9	014500632	1	紧定螺钉M5×6	Screw M5×6
10	152301901	1	针杆导向滑动曲柄	Slide block guide
11	152300301	1	螺钉SM4. 76-28×12	Screw SM4. 76-28×12
12	167301801	1	外圈滚针轴承BK0910	Bearing
13	152302001	1	螺钉SM4. 37-40×3	Screw SM4. 37-40×3
14	152303401	1	针杆摆动架	Needle rod rocking base
15	152303501	1	针杆摆动架轴	Needle rod rocking shaft
16	152302501	1	针杆摆动架组件	Needle rod rocking base assy
17	152302301	2	螺钉SM3. 57-40×10. 5	Screw SM3. 57-40×10. 5
18	152302401	1	摆动架导轨	Needle bar frame guide
19	152203201	1	螺母SM5. 95-28	Nut SM5. 95-28
20	152301601	1	垫圈6. 3	Washer 6. 3
21	152303201	2	紧定螺钉SM7. 14	Screw SM7. 14
22	152303101	1	针送布驱动下曲柄	Rock shaft ARM D
23	152301501	1	针送布驱动连杆接头	Connecting rod shaft
24	152301301	1	针送布驱动连杆	Connecting rod
25	152302701	1	螺钉SM4. 37-40×5	Screw SM4. 37-40×5
26	152203201	1	螺母SM5. 95-28	Nut SM5. 95-28
27	152302801	1	针送布驱动上曲柄	Rock shaft ARM U
28	152301201	1	驱动连杆轴位螺钉	Screw
29	152300301	1	螺钉SM4. 76-28×12	Screw SM4. 76-28×12
30	152300801	1	挡圈12. 7	Thrust collar12. 7
31	152300901	2	螺钉SM6. 35-40×4. 5	Screw SM6. 35-40×4. 5
32	152301001	1	针送布摆动后轴套	Rock shaft bushing back
33	152301101	1	垫圈12. 7	Washer 12. 7
34	048120142	1	轴用弹性挡圈12	Retaining ring 12