

序号	图号	数量	零件名称	NAME OF PARTS
1	062710812	3	螺钉 SM4. 76-28X9	SCREW SM4. 76-28X9
2	149010201	1	面板	PANEL
3	149010301	1	面板垫	PANEL PAD
4	115011401	2	橡皮塞 8.5	RUBBER STOPPER 8.5
5	101011001	2	橡皮塞 12.5	RUBBER STOPPER 12.5
6	115010401	1	后窗板	REAR WINDOW PANEL
7	062501016	9	螺钉 M5×10	SCREW M5×10
8	115010501	1	后窗板衬垫	REAR WINDOW PANEL PAD
9	168010901	1	橡皮塞 37.8	RUBBER STOPPER 37.8
10	168012101	1	马达罩	MATA HOOD
11	018502532	4	螺钉 M5×25	SCREW M5×25
12	115010701	2	橡皮塞 15.5	RUBBER STOPPER 15.5
13	101013201	2	螺钉 SM4. 37-40×5.5	SCREW SM4. 37-40×5.5
14	101012601	1	卷边器座	CRIMPER BASE
15	168011701	4	底板支柱	FLOOR STRUT
16	101011401	1	孔塞 20.9	HOLE PLUG 20.9
17	168012001	1	顶盖	COVER
18	168012501	5	螺钉 M3×8	SCREW M3×8
19	149011901	1	密封压板	SEALING PRESSURE PLATE
20	149012001	1	压杆密封垫	PRESSURE BAR GASKET
21	149054601	1	机头后罩	HEAD REAR COVER
22	149012202	1	后罩密封垫	REAR COVER GASKET
23	115023501	2	螺钉 SM4. 37-40X6	SCREW SM4. 37-40X6
24	115049101	4	橡皮塞 9.5	RUBBER STOPPER 9.5
25	149012301	1	螺钉 SM4. 37-40X6	SCREW SM4. 37-40X6
26	025050132	4	垫圈 5	WASHER 5
27	028060246	4	弹簧垫圈 T6	SPRING WASHER T6
28	101013301	1	孔塞 8.8	HOLE PLUG 8.8
29	101056001	4	螺钉 SM4. 76-28X12	SCREW SM4. 76-28X12

4. 送料装置/Feed mechanism components

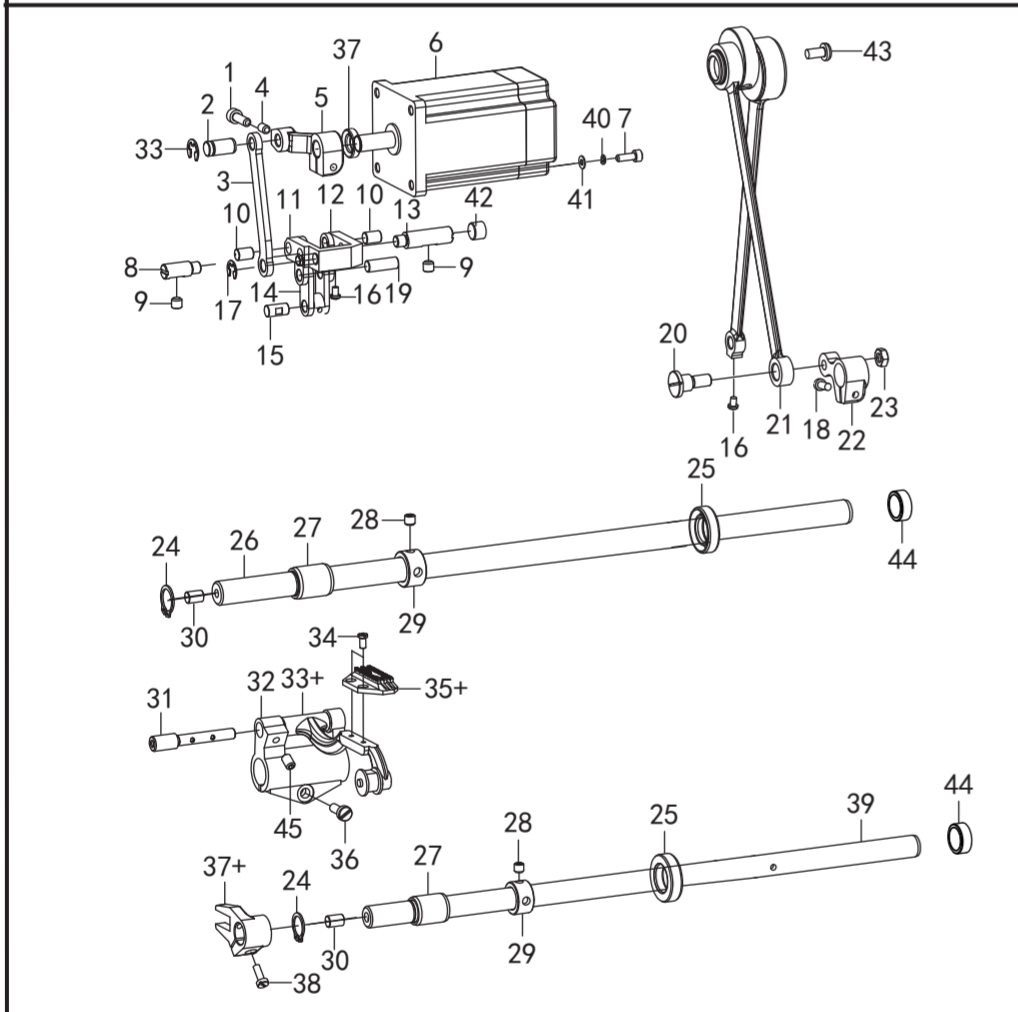

序号	图号	数量	零件名称	NAME OF PARTS
1	018502032	1	螺钉 M5×20	SCREW M5×20
2	168040201	2	连杆轴	CONNECTING ROD SHAFT
3	168040301	1	倒缝连杆	BACKSTITCH CONNECTING ROD
4	014680632	2	螺钉 SM4. 37	SCREW SM4. 37
5	168040501	1	倒缝曲柄	BACKSTITCH CRANK
6	168040602	1	倒缝步进电机 (琦星)	BACKSTITCH STEPPING MOTOR (QIXING)
7	018401832	4	螺钉 M4×16	SCREW M4×16
8	101061501	1	摆动板座左销	LEFT PIN OF SWING PLATE SEAT
9	101032401	2	螺钉 SM5. 95	SCREW SM5. 95
10	101061801	2	曲柄连杆短销	CRANK CONNECTING ROD SHORT PIN
11	168041101	1	切换器	KVM
12	101061602	1	曲柄短连杆	CRANK SHORT CONNECTING ROD
13	168041301	1	切换器右销	RIGHT SWITCH PIN
14	101061701	1	曲柄长连杆	LONG CRANK CONNECTING ROD
15	101060901	1	送料连杆销	FEED LINKAGE PIN
16	101062401	4	螺钉 SM3. 57	SCREW SM3. 57
17	048050342	1	卡簧 E5	CIRCLIP E5
18	103043501	1	螺钉 SM4. 76-28X14	SCREW SM4. 76-28X14
19	101063401	1	送料曲柄销	FEEDING CRANK PIN
20	101061101	1	连杆轴位螺钉	CONNECTING ROD AXIAL POSITION SCREW
21	101060102	1	连杆组件 H	CONNECTING ROD ASSEMBLY H
22	101063601	1	抬牙后曲柄	CRANK AFTER TOOTH LIFTING
23	101063701	1	螺母 SM5. 95	NUT SM5. 95
24	048140142	2	挡圈 C14	RETAINING RING C14
25	166201601	2	油封	OIL SEAL
26	168042601	1	送布轴	CLOTH FEEDING SHAFT
27	101063102	2	送布轴前轴套	FRONT SLEEVE OF CLOTH FEEDING SHAFT
28	101063001	4	螺钉 SM6. 35	SCREW SM6. 35
29	101062901	2	送布轴挡圈	CLOTH FEEDING SHAFT RETAINER RING
30	115082801	6	油毡	ASPHALT FELT
31	101062101	1	牙架	DENTAL FRAMEWORK
32	168043901	1	托牙轴	DENTURE SHAFT
33	101075201	1	挡圈 E5	RETAINING RING E5
34	115047001	2	螺钉 SM3. 18	SCREW SM3. 18
35+	115046901	1	送料牙 M	FEEDING TOOTH M
36	101062701	1	螺钉 SM5. 95	SCREW SM5. 95
37	169041101	1	油封	OIL SEAL
38	101064001	1	螺钉	SCREW
39	168043901	1	抬牙轴	TOOTH LIFTING SHAFT
40	028040246	4	弹簧垫圈 T4	SPRING WASHER T4
41	025040132	4	平垫圈 4	FLAT WASHER 4
42	115011001	1	橡皮塞 10.5	RUBBER STOPPER 10.5
43	101060601	2	偏心轮螺钉	ECCENTRIC SCREW
44	125013001	2	橡皮塞 15.2	RUBBER STOPPER 15.2
45	101062601	1	螺钉 SM4. 37-40X7	SCREW SM4. 37-40X7

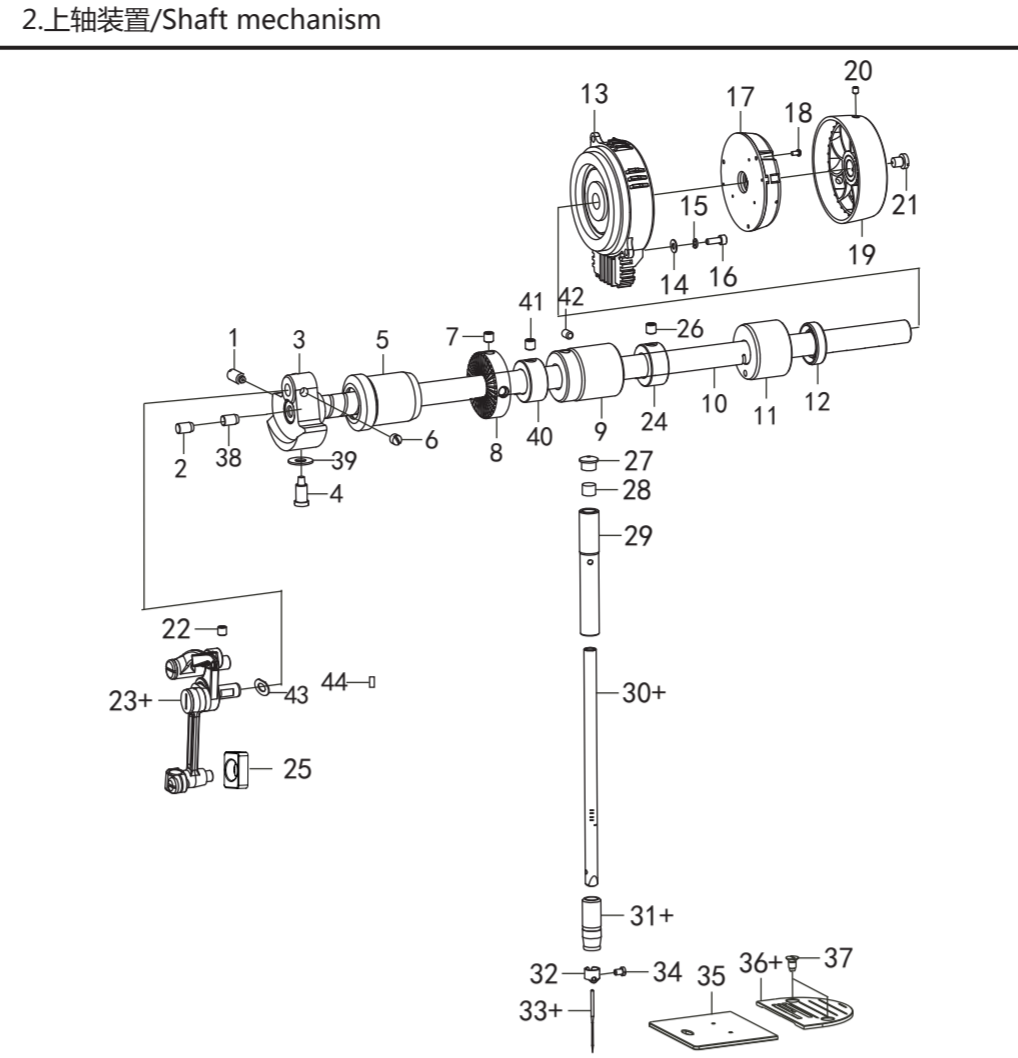

序号	图号	数量	零件名称	NAME OF PARTS
1	101031601	1	螺钉 SM7. 14	SCREW SM7. 14
2	101031901	2	橡皮塞 6.8	RUBBER STOPPER 6.8
3	149020301	1	针杆曲柄	NEEDLE BAR CRANK
4	101031801	1	螺钉 SM7. 14	SCREW SM7. 14
5	149020501	1	上轴前轴套	FRONT SHAFT SLEEVE OF UPPER SHAFT
6	101031701	2	螺钉 SM6. 35	SCREW SM6. 35
7	014500832	2	螺钉 M5×8	SCREW M5×8
8	101032101	1	绕线驱动轮	WINDING DRIVE WHEEL
9	168020901	1	上轴中轴套	UPPER SHAFT MIDDLE SHAFT SLEEVE
10	152206201	1	上轴	UPPER AXIS
11	168021102	1	上轴后轴套	UPPER SHAFT REAR SHAFT SLEEVE
12	115024001	1	油封	OIL SEAL
13	168021302	1	马达组件	MOTOR ASSEMBLY
14	028050246	3	弹性垫圈	SPRING WASHER
15	025050132	3	垫圈 M5	WASHER M5
16	018501432	3	螺钉 M5×14	SCREW M5×14
17	115020101	1	编码器	ENCODER
18	062350516	3	螺钉 M5×5	SCREW M5×5
19	115025303	1	手轮	HANDWHEEL
20	012501032	2	螺钉 M5×10	SCREW M5×10
21	115025401	1	螺钉 SM8. 73	SCREW SM8. 73
22	012061032	1	螺钉 M6×10	SCREW M6×10
23+	101031401	1	挑线杆组件 M	THREAD TAKE-UP LEVER ASSEMBLY M
24	101032501	1	上轴挡圈	UPPER SHAFT RETAINER RING
25	115020201-1	1	针杆滑块	NEEDLE BAR SLIDER
26	115024801	2	螺钉 SM4. 37-40X6	SCREW SM4. 37-40X6
27	115010801	1	橡皮塞 8.5	RUBBER STOPPER 8.5
28	115025601	1	油毡	ASPHALT FELT
29	101040301	1	针杆上套	NEEDLE BAR UPPER SLEEVE
30	101040403	1	针杆 M	NEEDLE BAR M
31	101040901	1	针杆下套 M	NEEDLE BAR LOWER SLEEVE M
32	149023201	1	针杆过线环	NEEDLE BAR THREAD PASSING RING
33+	115024101	1	机针 DBX 1 14	NEEDLE DBX1 14
34	101041001	1	支针螺钉 SM3. 18	NEEDLE SCREW SM3. 18
35	101011801	1	推板组件	PUSH PLATE ASSEMBLY
36+	115023401	1	针板 M	NEEDLE PLATE M
37	115023501	2	螺钉 SM4. 37	SCREW SM4. 37
38	101034102	1	上轴油毡	UPPER SHAFT FELT
39	115085301	1	O型圈 9. 3X2. 4	O-RING 9. 3X2. 4
40	101062901	1	送料挡圈	FEEDING RETAINER RING
41	014770632	2	螺钉 SM6. 35-40X6	SCREW SM6. 35-40X6
42	014760832	1	螺钉 SM5. 95	SCREW SM5. 95
43	115021402	1	垫圈 8	WASHER 8
44	101030601	1	挑线杆防油套	OIL PROOF SLEEVE

5. 摆动部件/Swinging parts

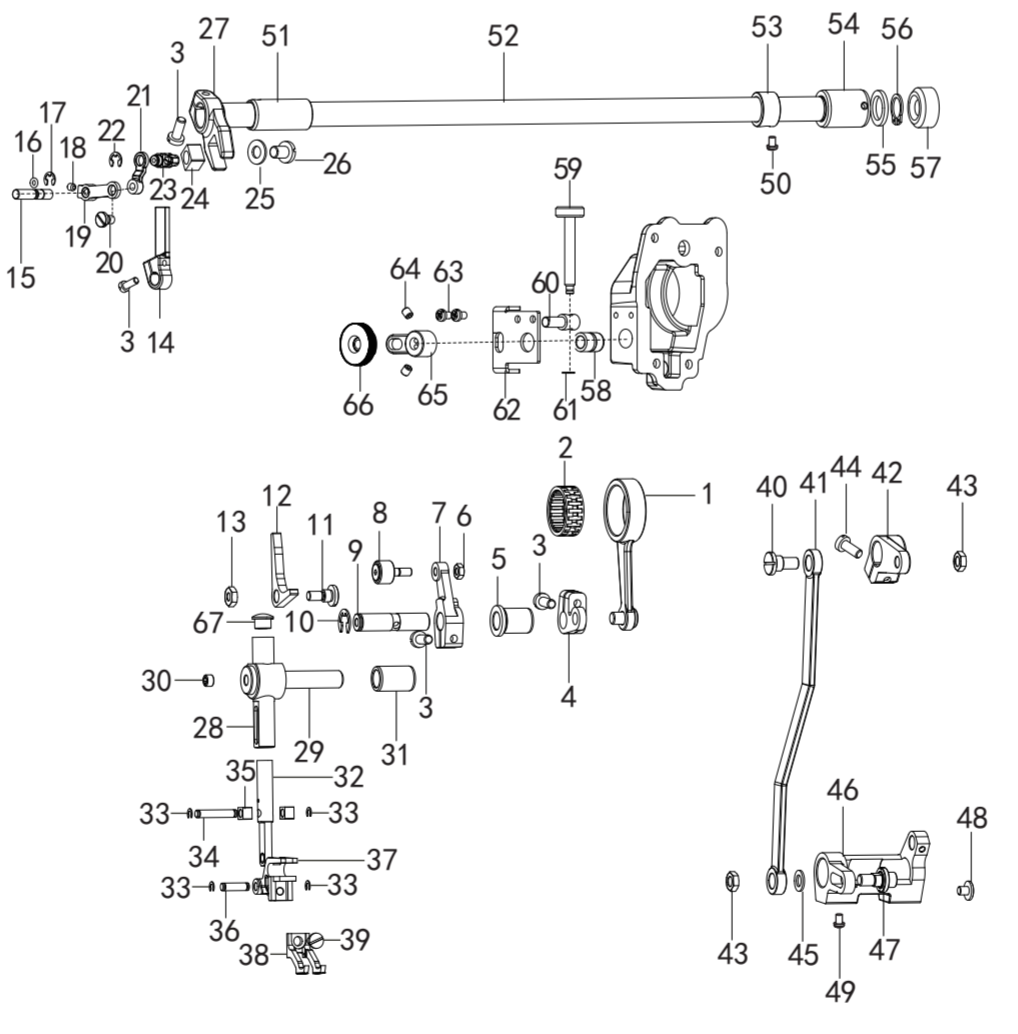

序号	图号	数量	零件名称	NAME OF PARTS
1	149050101	1	偏心连杆	ECCENTRIC CONNECTING ROD
2	149050201	1	滚针轴承	NEEDLE BEARING
3	101062701	3	螺钉 SM4. 76-28X12	SCREW SM4. 76-28X12
4	149051501	1	偏心后曲柄	ECCENTRIC REAR CRANK
5	149051001	1	摆动套 U	SWING SLEEVE U
6	021400312	1	螺母 M4	NUT M4
7	149050401	1	偏心前曲柄	ECCENTRIC FRONT CRANK
8	149050501	1	轴承滚轮	BEARING ROLLER
9	149051101	1	偏心摆动轴	ECCENTRIC OSCILLATING AXLE
10	048070342	1	挡圈 E7	RETAINING RING E7
11	149050701	1	轴位螺钉 SM4. 76-32x8.5	SHAFT POSITION SCREW SM4. 76-32X8.5
12	149050601	1	压脚抬升杆	PRESSER FOOT LIFTING LEVER
13	149050801	1	螺母 SM4. 76X32	NUT SM4. 76X32
14	149053201	1	压脚摆动曲柄	PRESSER FOOT SWINGING CRANK
15	149054101	1	调节轴	ADJUSTING SHAFT
16	048050342	1	卡簧 E2. 5	CIRCLIP E2. 5
17	081004070	1	O型圈 P4	O-RING P4
18	014500532	1	螺钉 M5X5	SCREW M5X5
19	149054001	1	内调节曲柄	INTERNAL ADJUSTING CRANK
20	101052301	1	后杠杆轴位螺钉	REAR LEVER AXIAL POSITION SCREW
21	149053601	1	摆动连杆	OSCILLATING LINK
22	048060342	1	卡簧 E6	CIRCLIP E6
23	149054501	1	调节座组件	ADJUSTING BASE ASSEMBLY
24	149053401	1	调节座滑块	ADJUSTING SEAT SLIDER
25	149054801	1	垫圈 9X4. 5	WASHER 9X4. 5
26	125080501	1	螺钉 SM4. 67-40X6	SCREW SM4. 67-40X6
27	149053102	1	压脚摆动叉	PRESSER FOOT SWING FORK
28	149051801	1	压脚摆动衬套	PRESSER FOOT SWING BUSHING
29	149051901	1	压脚摆动架	PRESSER FOOT SWING FRAME
30	149052001	1	螺钉 SM5. 95-28X4	SCREW SM5. 95-28X4

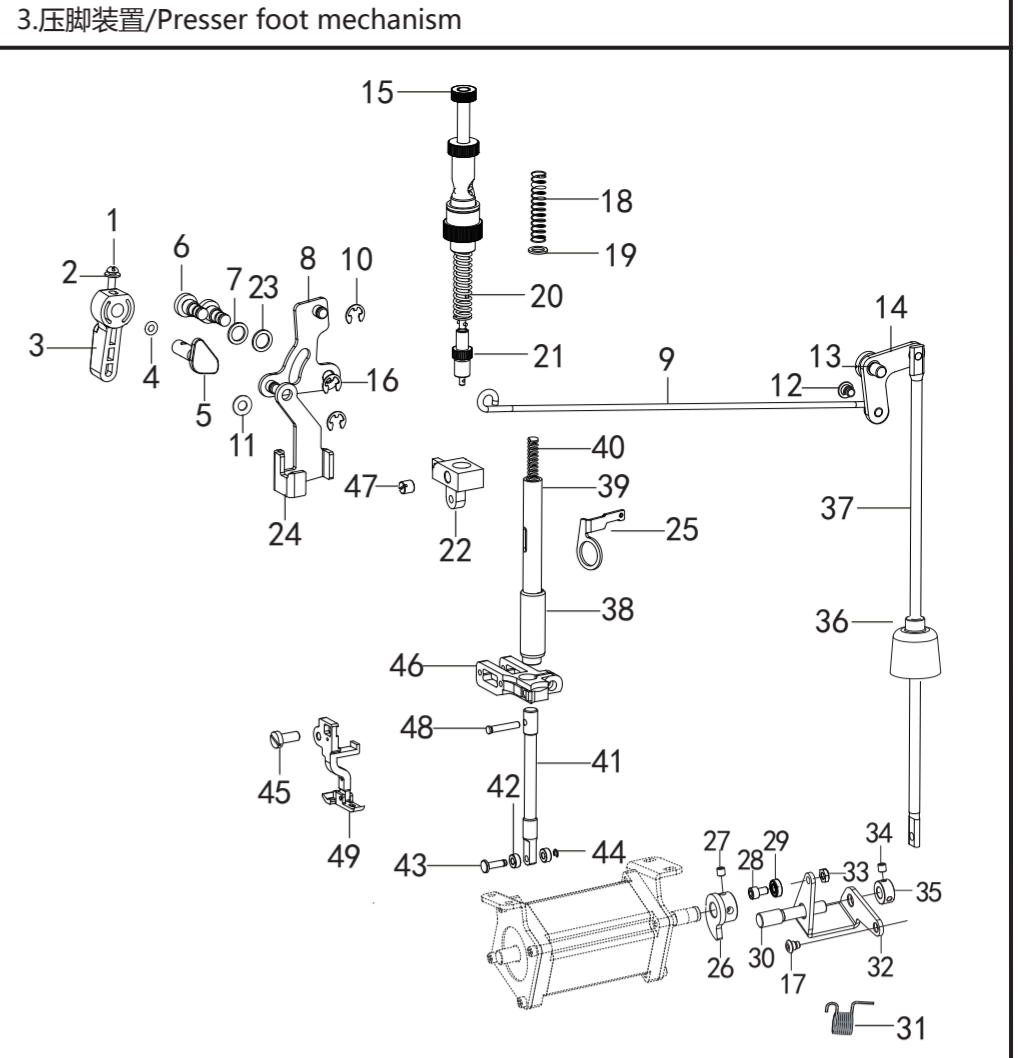

序号	图号	数量	零件名称	NAME OF PARTS
1	101054501	1	螺钉 SM3. 57	SCREW SM3. 57
2	101054601	1	垫圈 3.7	WASHER 3.7
3	168030301	1	抬压脚扳手	PRESSER FOOT LIFTING WRENCH
4	081004070	1	O型圈 P4	O-RING P4
5	149030501	1	抬压脚凸轮	PRESSER FOOT LIFTING CAM
6	101052001	2	前杠杆螺纹销	FRONT LEVER THREADED PIN
7	101052101	1	防油橡胶垫 (薄)	OIL PROOF RUBBER PAD (THIN)
8	101051501	1	抬压脚前杠杆	FRONT LEVER FOR PRESSER FOOT LIFT
9	149030901	1	抬压脚拉杆	PRESSER FOOT LIFT ROD
10	048050342	1	卡簧 E5	CIRCLIP E5
11	101056301	2	垫圈 6.35	WASHER 6.35
12	115034301	2	轴位螺钉 SM4. 76	SHAFT POSITION SCREW SM4. 76
13	115034501	1	轴位螺钉 SM6. 35	SHAFT POSITION SCREW SM6. 35
14	167052401	1	抬压脚后杠杆	REAR LEVER FOR PRESSER FOOT LIFT
15	149031501	1	调节压脚组件	PRESSURE REGULATING SCREW ASSEMBLY
16	101075201	2	卡簧 E5	CIRCLIP E5
17	168031301	1	轴位螺钉 SM4. 76x32	SHAFT POSITION SCREW SM4. 76X32
18	149031801	1	压力调节复位簧	PRESSURE REGULATING RESET SPRING
19	149031901	1	垫圈 6.5	WASHER 6.5
20	149032001	1	调节簧	PRESSURE REGULATING SPRING
21	149032101	1	调节器组件	REGULATOR AS
22	149032201	1	压杆导架组件	PRESSER BAR GUIDE ASSEMBLY
23	101052701	2	防油橡胶垫 (厚)	OIL PROOF RUBBER PAD (THICK)
24	149035301	1	压脚升降板	PRESSER FOOT LIFTING PLATE
25	149035202	1	松线顶杆	LOOSE LINE ROD
26	169033301	1	抬压脚凸轮	PRESSER FOOT LIFTING CAM
27	014600632	2	螺钉 M6-0. 75X6	SCREW M6-0. 75X6
28	018601232	1	螺钉 M6-0. 75X12	SCREW M6-0. 75X12
29	169034001	1	轴承	BEARING
30	168033101	1	抬压脚曲柄轴	PRESSER FOOT LIFTING CRANK SHAFT
31	168033801-1	1	压脚复位簧	PRESSER FOOT RESET SPRING
32	168033201	1	抬压脚驱动曲柄	PRESSER FOOT LIFT DRIVE CRANK
33	021600306	1	螺母 M6×0. 75	NUT M6×0. 75
34	152201701	2	螺钉 SM4. 37-40X4	SCREW SM4. 37-40X4
35	168033501	1	曲柄轴挡圈	CRANKSHAFT RETAINER RING
36	168033601	1	膝控提升杆橡皮塞	RUBBER STOPPER
37	168033701	1	抬压脚顶杆	PRESSER FOOT LIFTER
38	149033801	1	压杆衬套	PRESSING ROD BUSHING
39	149033901	1	压杆	PRESSURE BAR
40	149034001	1	压脚复位簧	PRESSER FOOT RESET SPRING
41	149034101	1	压脚提升轴	PRESSER FOOT LIFTING SHAFT
42	149034201	2	压脚滚轮	PRESSER FOOT ROLLER
43	149034301	1	压脚滚轴轴套	PRESSER FOOT ROLLER SHAFT
44	048025342	1	挡圈 E2. 5	RETAINING RING E2. 5
45	101062701	1	螺钉 SM4. 76-28X12	SCREW SM4. 76-28X12
46	149034601	1	压脚滑块导架	PRESSER FOOT SLIDER GUIDE
47	115024801	1	螺钉 SM6. 35-40X8	SCREW SM6. 35-40X8
48	149035001	1	压脚抬升销	PRESSER FOOT LIFTING PIN
49	149035101	1	压脚组件	PRESSER FOOT ASSEMBLY

序号	图号	数量	零件名称	NAME OF PARTS
31	149053001	1	摆动套 D	SWING SLEEVE D
32	149052101	1	压脚摆动杆	PRESSER FOOT SWINGING ROD
33	149052301	4	挡圈 C3. 2	RETAINING RING C3. 2
34	149052401	1	压脚长销	PRESSER FOOT LONG PIN
35	149052201	2	滑块	SLIDER
36	149052601	1	压脚短销	PRESSER FOOT SHORT PIN
37	149052701	1	滚轮导架	ROLLER GUIDE
38	149052801	1	摆动压脚	SWING PRESSER FOOT
39	149035401	1	压脚螺钉 SM4. 37	PRESSER FOOT SCREW SM4. 37
40	152301201	1	偏驱动连杆轴位螺钉	CONNECTING ROD AXIAL POSITION SCREW
41	152301301	1</		

6.旋梭装置/ Hook components

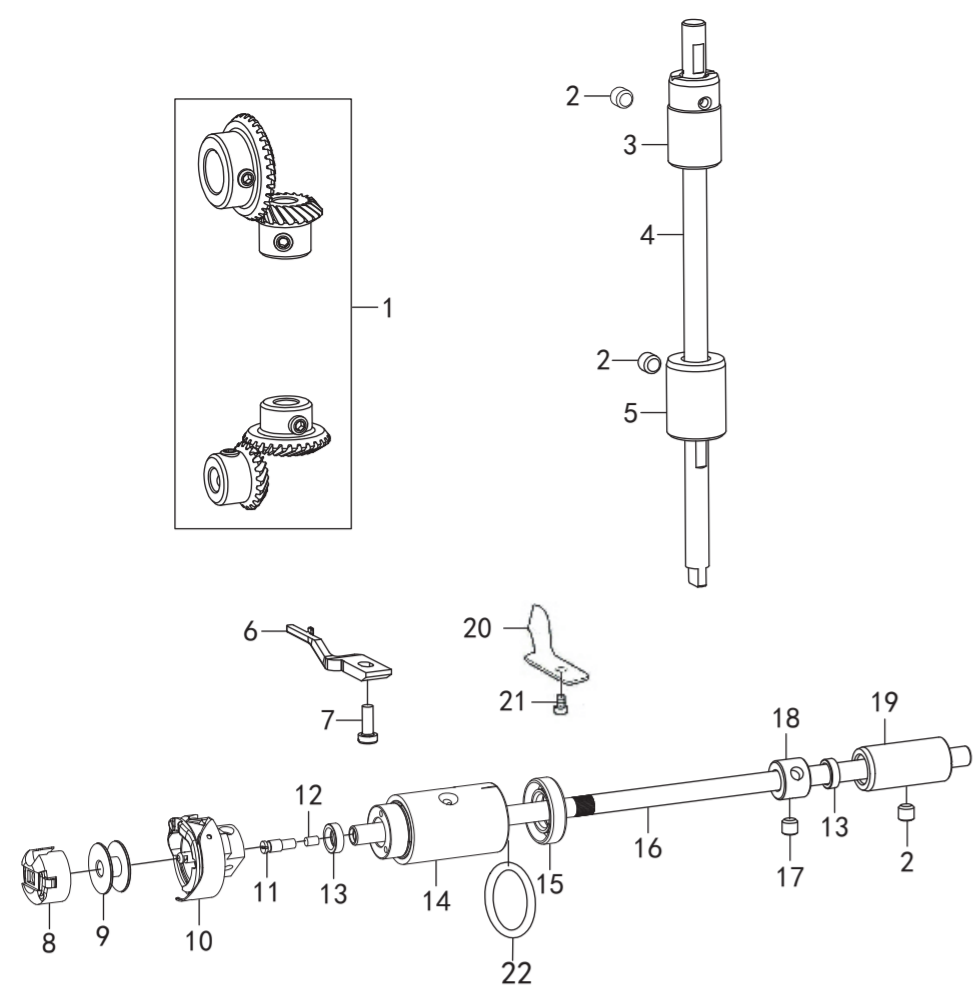

序号	图号	数量	零件名称	NAME OF PARTS
1	101041303	1	伞齿轮组件	BEVEL GEAR ASSY
2	014760832	3	螺钉 SM5. 95	SCREW SM5. 95
3	168050301	1	竖轴上轴套	VERTICAL SHAFT BUSH U
4	101041902	1	竖轴	VERTICAL SHAFT
5	168050501	1	竖轴下轴套	VERTICAL SHAFT BUSH D
6	115072204	1	旋梭定位钩	HOOK STOPPER
7	115072601	1	螺钉 SM4. 37	SCREW PAN SM4. 37
8	115072701	1	梭芯套组件	BOBBIN GASE ASSY
9	115072401	1	梭芯	BOBBIN
10	115072312	1	旋梭组件	ROTARY HOOK ASSY
11	115071401	1	油盖螺钉	OIL COVER SCREW
12	115071901	1	油芯	OIL CORE
13	115073401	2	油封	OIL SEAL
14	168051401	1	下轴前套	PUMP BUSH
15	115071601	1	油封	OIL SEAL
16	101042901	1	旋梭轴	ROTARY HOOK SHAFT
17	014770532	2	螺钉 SM6. 35	SCREW PAN SM6. 35
18	115072001	1	紧圈	SET SCREW COLLAR
19	168051901	1	下轴后轴套	BUSHING THREAD FINGER
20	125082201	1	分线器	LOWER THREAD FINGER
21	101080701	1	螺钉 SM3. 57	SCREW PAN SM3. 57
22	115073301	2	O型圈	O-RING

7.穿线装置/Threading mechanism

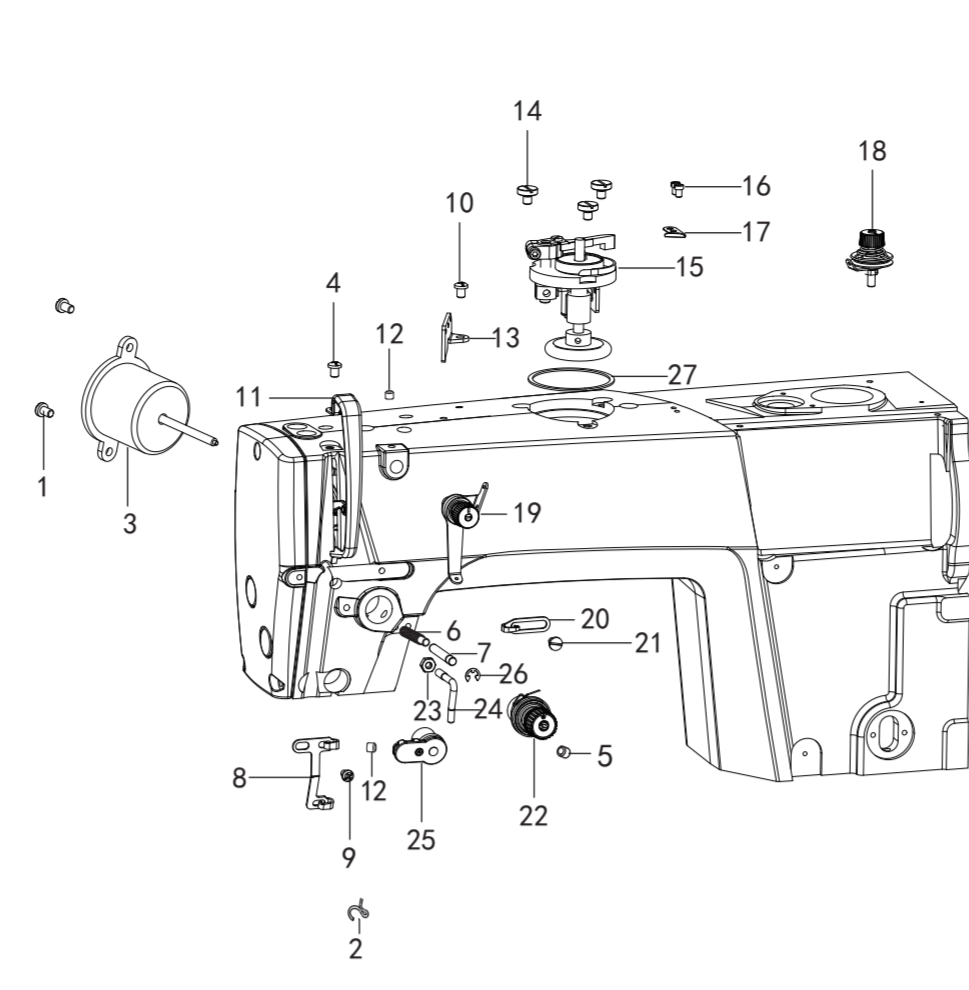

序号	图号	数量	零件名称	NAME OF PARTS
1	062400616	2	螺钉 M4×6	SCREW M4×6
2	115091401	1	线导向	WIRE GUIDE
3	149053701	1	松线电磁铁组件	WIRE LOOSENING ELECTROMAGNET ASM
4	062710812	1	螺钉 SM4. 76-28X9	SCREW SM4. 76-28X9
5	101020401	1	螺钉 SM5. 95-28X7	SCREW SM5. 95-28X7
6	169122701	1	松线复位簧	RELEASE PIN RETURN SPRING
7	149070701	1	松线复位销	LOOSE THREAD RESET PIN
8	180090201	1	面线线钩	SURFACE LINE HOOK
9	125022201	1	螺钉 M4×6	SCREW M4×6
10	101010901	1	螺钉 SM4. 76	SCREW SM4. 76
11	101010801	1	挑线杆防护罩	THREAD TAKE-UP GUARD
12	101022201	2	螺钉 SM4. 76	SCREW SM4. 76
13	115090301	1	穿线板	THREADING PLATE
14	101022601	3	螺钉 M5×10	SCREW M5×10
15	101022501	1	绕线器组件	WINDER ASSEMBLY
16	101022801	2	螺钉 SM3. 57	SCREW SM3. 57
17	101022701	1	切刀	CUTTER
18	168073101	1	绕线器夹线组件	WINDING CLAMP ASSEMBLY
19	168072201	1	调线夹线器组件	CABLE ADJUSTING CLAMP ASSEMBLY
20	101020701	1	右线勾	RIGHT LINE TICK
21	101020201	1	螺钉 SM4. 37-40x6	SCREW SM4. 37-40X6
22	168072501	1	夹线器组件 M	WIRE CLAMP ASSEMBLY M
23	115111601	1	螺钉 SM5. 95	SCREW SM5. 95
24	101020502	1	大线勾	LARGE LINE HOOK
25	166072501	1	电子夹线器	ELECTRONIC WIRE CLAMP
26	048040342	1	挡圈E4	RETAINING RING E4
27	168072901	1	绕线器密封垫	WINDER GASKET

8.切线装置/Thread trimmer mechanism

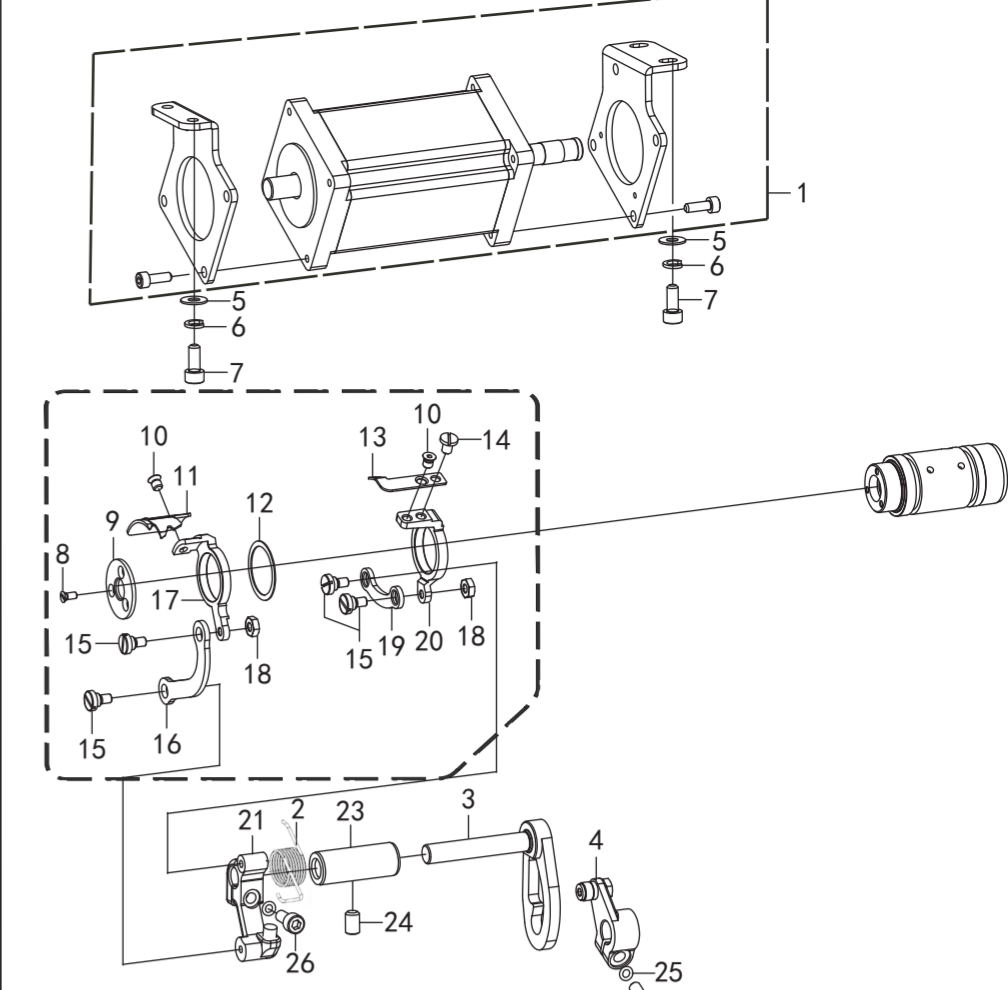

序号	图号	数量	零件名称	NAME OF PARTS
1	168080202	1	剪线电机	MOTOR
2	125082301	1	动力复位簧	MOVBLE KINFIE RESET SPRING
3	168082001	1	切线曲柄	THREAD TRIMMER LEVER
4	169110102	1	切线驱动曲柄	THREAD TRIMMER CAM LEVER SHAFT
5	025050132	4	垫圈 M5	WASHER M5
6	028050246	4	弹簧垫圈	SPRING WASHER
7	018501432	4	螺钉 M5×14	SCREW PAN M5×14
8	125080401	3	螺钉 M3×5	SCREW PAN M3×5
9	125082501	1	动力压板	KNIFE HOLLDER PRESSER PLATE
10	115111301	3	螺钉 SM4. 37	SCREW PAN SM4. 37
11	125081501	1	下动刀	MOVABLE KNIFEL D
12	125081801	1	垫圈	WASHER
13	125081401	1	上动刀	MOVABLE KNIFEL U
14	125080501	1	螺钉 SM4. 37	SCREW PAN SM4. 37
15	125080601	4	螺钉 M4	SCREW PAN M4
16	125082001	1	刀架长连杆	KNIFE HOLLDER CONNECTING ROD L
17	125081701	1	下刀架	HOLER M-KNIFE D
18	021400306	2	螺母 M4	NUT M4
19	125081901	1	刀架短连杆	KNIFE HOLLDER CONNECTING ROD S
20	125081601	1	上刀架	HOLER M-KNIFE U
21	125082101	1	切线曲柄	THREAD TRIMMER LEVER
22	018501432	1	螺钉 M5×14	SCREW M5×14
23	125082401	1	切刀轴套	FORKED SHAFT BUSH
24	014760832	1	螺钉 SM5. 95	SCREW PAN SM5. 95
25	028050246	2	弹簧垫圈T5	SPRING WASHER T5
26	101081901	1	螺钉SM4. 76-32X14	SCREW SM4. 76-32X14

9.供油润滑装置/Lubrication

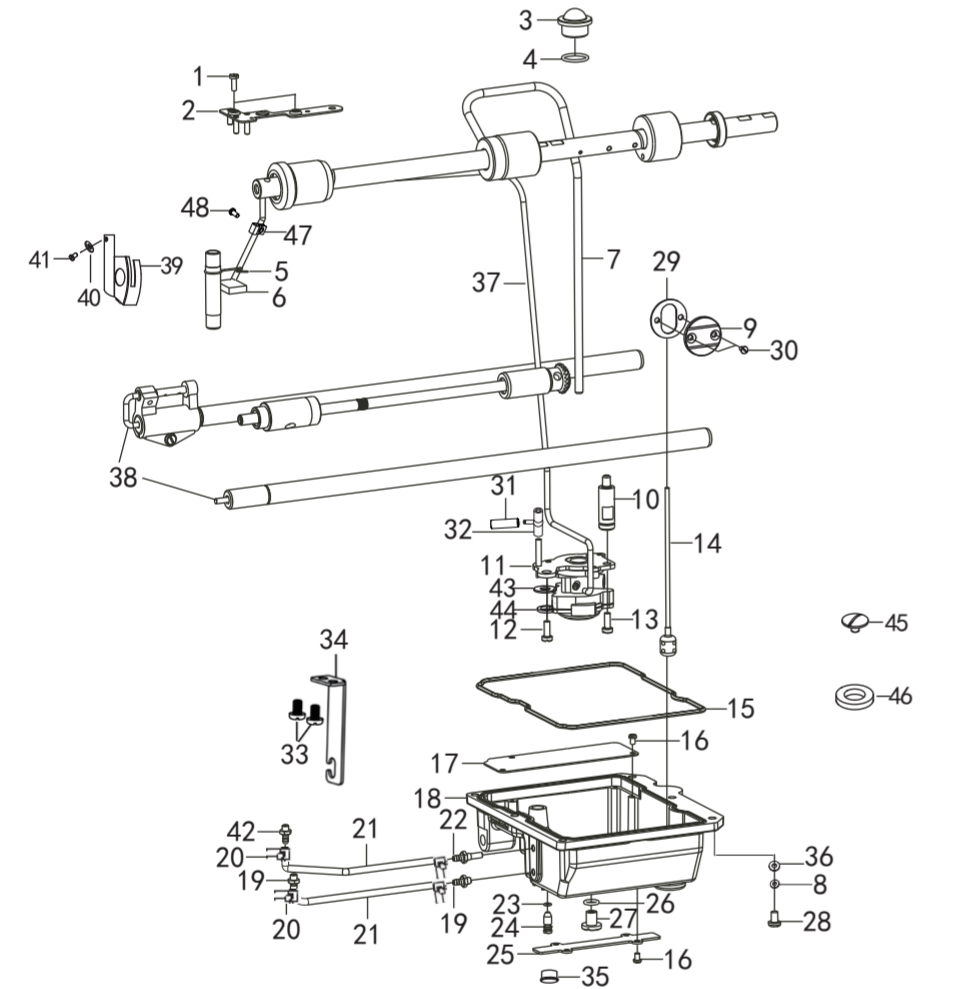

序号	图号	数量	零件名称	NAME OF PARTS
1	115031001	2	螺钉 SM3. 57	SCREW SM3. 57
2	101090701	1	油线固定板	OIL LINE FIXING PLATE
3	101090901	1	油窗	OIL WINDOW
4	101091001	1	油窗垫片	OIL WINDOW GASKET
5	101090601	1	油毡夹	LINOLEUM CLIP
6	101090301	1	油毡	LINOLEUM
7	149080701	1	上轴供油管	UPPER SHAFT OIL SUPPLY PIPE
8	028050246	6	弹簧垫圈T5	SPRING WASHER T5
9	168063401	1	油量视窗板	OIL VOLUME WINDOW PANEL
10	101091601	1	油泵连接螺钉	OIL PUMP CONNECTING SCREW
11	168061401	1	油泵组件	OIL PUMP COMPONENTS
12	101074701	1	螺钉 SM5. 95	SCREW SM5. 95
13	115072601	1	螺钉 SM4. 37	SCREW SM4. 37
14	180085401	1	浮球组件	FLOAT ASSEMBLY
15	168061802	1	油盒密封圈	OIL BOX SEALING RING
16	062350616	7	螺钉 M3. 5×6	SCREW M3. 5×6
17	168062002	1	油盒盖	OIL BOX COVER
18	168062102	1	油盒	OIL BOX
19	115080401	2	供油口	OIL SUPPLY PORT
20	115085501	4	油管夹	TUBING CLAMP
21	5040202	2	尼龙油管3. 2(230mm)	NYLON TUBING 3. 2 (230MM)
22	168062601	1	供油口	OIL SUPPLY PORT
23	081004870	2	O型圈 6. 5X1. 5	O-RING 6. 5X1. 5
24	115081501	1	调节螺钉	ADJUSTING SCREW
25	124123201	1	电线压板	WIRE PRESSURE PLATE
26	168063001	1	O型圈13x2. 4	O-RING 13X2. 4
27	115080901	1	放油螺钉 M8	OIL DRAIN SCREW M8
28	018502032	6	螺钉 M5×20	SCREW M5×20
29	168063501	1	油窗防油垫	OIL WINDOW OIL PAD
30	168063801	2	螺钉SM3. 57×40-6	SCREW SM3. 57×40-6
31	125092201	1	铝管接头	ALUMINUM PIPE JOINT
32	101091701	1	供油管接头	OIL SUPPLY PIPE JOINT
33	062500816	2	螺钉M5×8	SCREW M5×8
34	169080101	1	油管支架	TUBING BRACKET
35	115011001	1	橡皮塞10. 5	RUBBER STOPPER 10. 5
36	025050132	6	垫圈5	WASHER 5
37	5040202	1	尼龙油管3. 2(670mm)	NYLON TUBING 3. 2 (670MM)
38	101092201	2	油线	OIL LINE
39	125091301	1	面部防油板	FACE OIL REPELLENT
40	101054601	1	平垫圈3. 7	FLAT WASHER 3. 7
41	101090101	1	螺钉SM3. 18-44X4	SCREW SM3. 18-44X4
42	125101802	1	回油接头	OIL RETURN CONNECTOR
43	101075101	1	平垫圈6	FLAT WASHER 6
44	028606246	1	弹簧垫圈T6	SPRING WASHER T6
45	125103901	1	磁铁安装螺钉	MAGNET MOUNTING SCREW
46	5050951	1	磁铁	MAGNET
47	101090401	1	回油管夹	OIL RETURN PIPE CLAMP
48	062670712	1	螺钉SM3. 57-40X7	SCREW SM3. 57-40X7

10.倒缝开关装置/Quick reverse switch mechanism

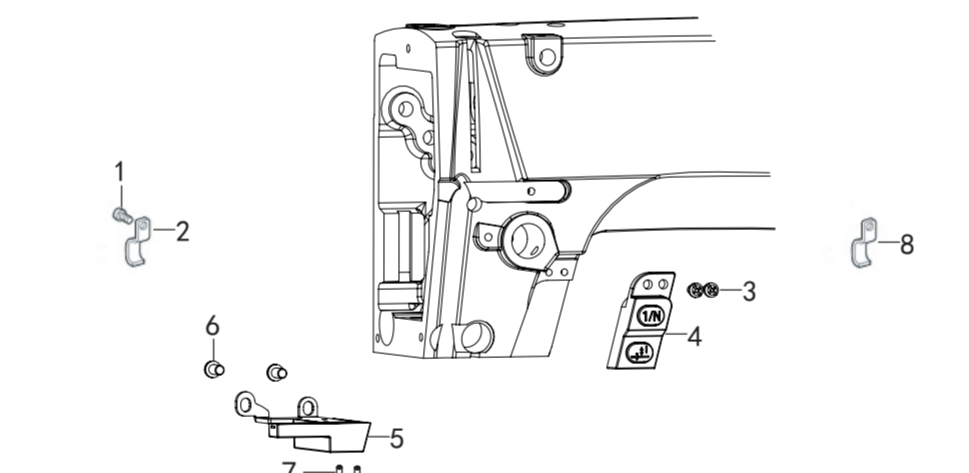

11.控制部分/Control components

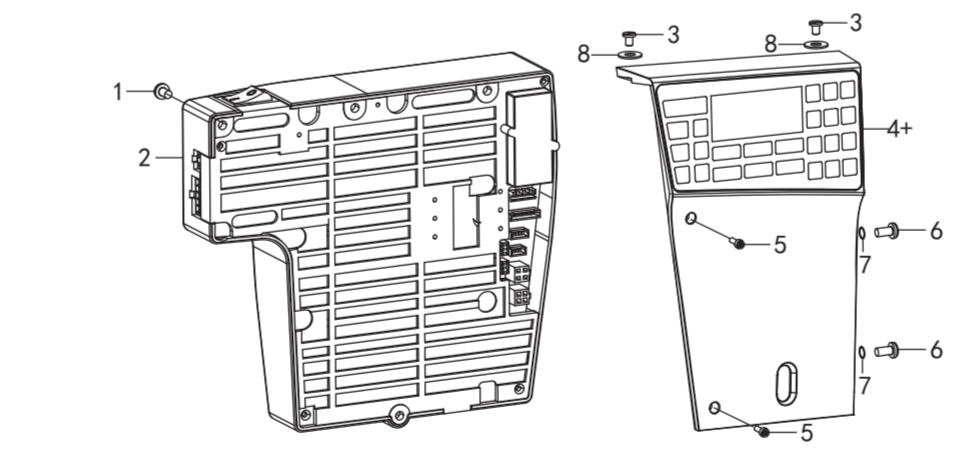

序号	图号	数量	零件名称	NAME OF PARTS
1	062500816	1	螺钉 M5×8	SCREW PAN M5×8
2	102110201	1	电线压板	WIRE PRESSING PLATE
3	062400616	2	螺钉M4×8	SCREW PAN M4X8
4	149090101	1	补针开关组件	NEEDLE COMPENSATE SWITCH
5	149090401	1	倒缝开关组件	R-SWICH ASSY
6	101010901	2	螺钉SM4. 76-28x6	SCREW PAN SM4. 76-28X6
7	062300516	2	螺钉M3X5	SCREW PAN M3X5
8	115140301	1	电线夹 U2	CORD HOLDER U2

序号	图号	数量	零件名称	NAME OF PARTS
1	102030301	3	螺钉 M5×18	SCREW PAN M5×18
2	168101501	1	控制箱	CONTROL BOX ASSY
3	101020201	2	螺钉 SM4. 37×40-6	SCREW PAN SM4. 37×40-6
4+	166100401	1	操作盒组件	OPERATION PANEL
4+	168100704	1	操作屏组件	OPERATION SCREEN COMPONENTS
5	168012501	2	螺钉 M3×8	SCREW PAN M3×8
6	062500816	2	螺钉 M5×8	SCREW PAN M5×8
7	025050132	2	平垫圈5	WASHER 5
8	025050132-1	2	平垫圈5	WASHER 5

12.附件/Accessories

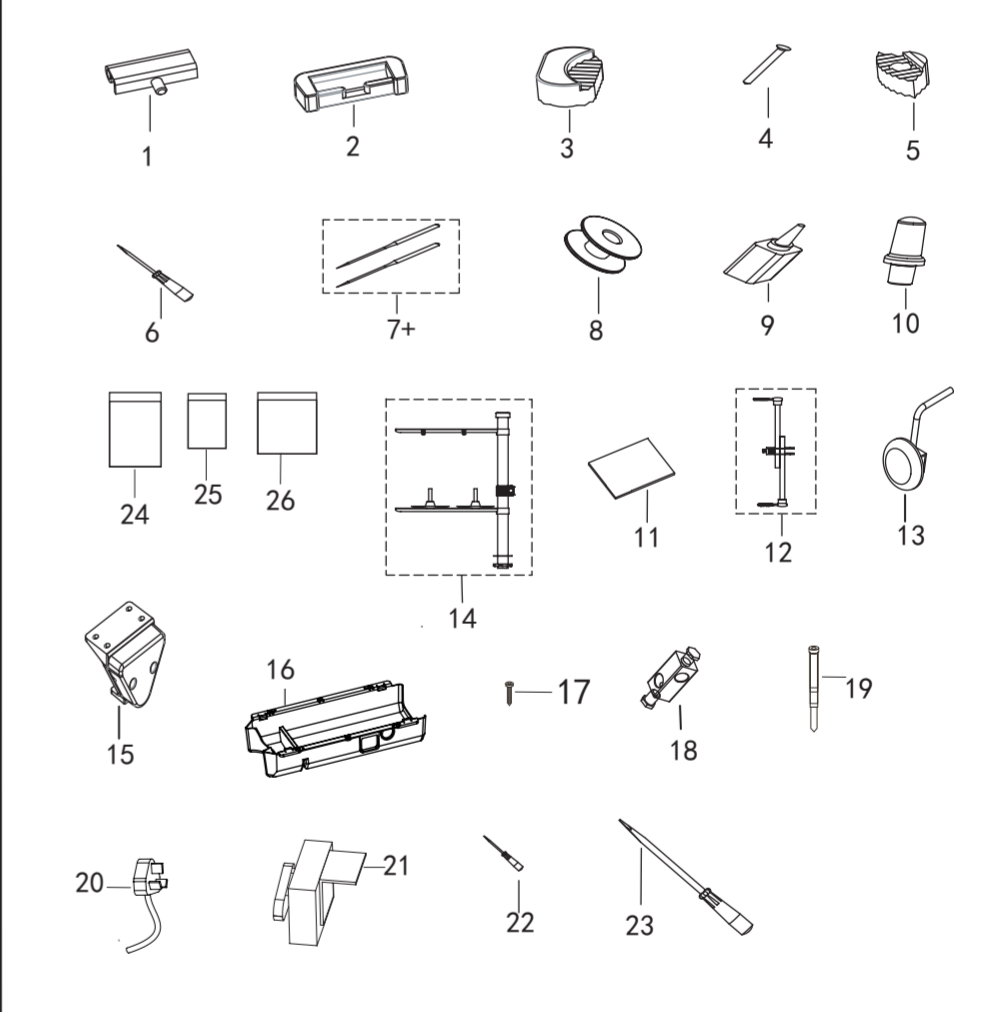

序号	图号	数量	零件名称	NAME OF PARTS
1	115150401	2	机头铰链	HEAD HINGE
2	101120501	2	机头铰链套	HEAD HINGE SLEEVE
3	125120601	2	头部防震垫	HEAD SHOCK PAD
4	5050111	4	钉	NAIL
5	125120801	2	头部防震垫	HEAD SHOCK PAD
6	115151701	1	螺丝刀(中)	SCREWDRIVER (MEDIUM)
7+	115024112	4	机针DB×1 14	NEEDLE DB×114
7+	115072401	10	机针DP× 5 20	NEEDLE DP× 5 20
8	115151001	3	梭芯	BOBBIN
9	115024113	1	中号油壶	MEDIUM OIL CAN
10	168111401	1	机头撑杆	HEAD SUPPORT
11	6040101	1	机头罩	HOOD
12	115151901	1	连杆组件	CONNECTING ROD ASSEMBLY
13	125104001	1	膝控组件	KNEE CONTROL COMPONENTS
14	115151401	1	线架组件 ZDR	WIRE RACK ASSEMBLY 2DR
15	169050101	1	电子膝靠组件	ELECTRONIC KNEE REST
16	125103101	1	油盒	OIL PAN
17	152208101	12	木螺钉ST4. 2X25	WOOD SCREW ST4. 2X25
18	125104101	1	膝控接头	KNEE JOINT
19	5040104	3	扎带	TIE
20	125122801	1	电源线	POWER CABLE
21	115152001	1	调速器	GOVERNOR
22	115151601	1	螺丝刀(小)	SCREWDRIVER (SMALL)
23	115151801	1	螺丝刀(大)	SCREWDRIVER (LARGE)
24	115160601	1	自封袋	ZIPLCLOCK BAG
25	115160701	1	自封袋	ZIPLCLOCK BAG
26	115160801	1	自封袋	ZIPLCLOCK BAG